



Scharnieren Charnières

C1.2

C1.2: 1106810

Onderbordscharnier losse delen / Charnière de ridelle pièces détachées

Stalen inlegplaat gegalvaniseerd.
Gewicht: 0,10 kg

Plaque d'insertion, acier galvanisé
pour 1106821.
Poids: 0,10 kg

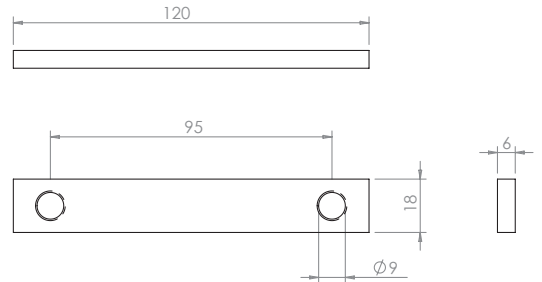

C1.2: 1106812

Veiligheidsonderbordscharnier / Charnière de ridelle de sécurité

Houder voor veiligheidsonderbord-
scharnier.
Gewicht: 0,30 kg

Support pour charnière de panneau
inférieur de sécurité.
Poids: 0,30 kg

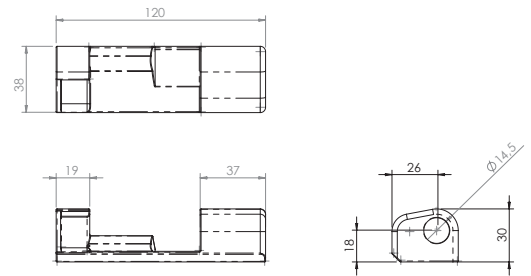
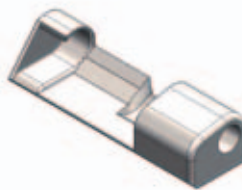

C1.2: 1106813

Veiligheidsonderbordscharnier / Charnière de ridelle de sécurité

Pen met lage borst type 1106811.
Gewicht: 0,26 kg

Axe à collerette basse, type 1106811.
Poids: 0,26 kg

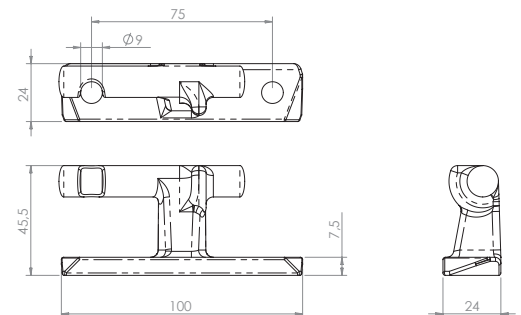
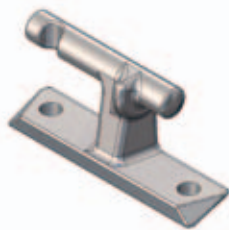

C1.2: 1106815

Onderbordscharnier losse delen / Charnière de ridelle pièces détachées

Inlegplaatje gegalvaniseerd, voor
1106805.
Gewicht: 0,09 kg

Plaque d'insertion galvanisé, pour
1106805.
Poids: 0,09 kg

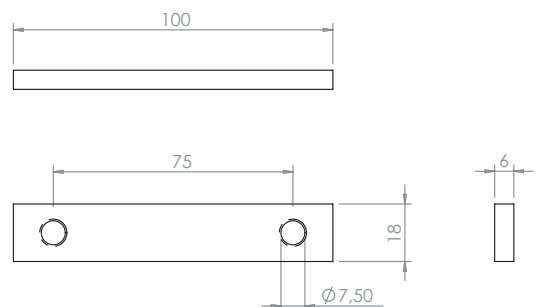



Onderbordscharnier sets / Charnière de ridelle ensembles

C1.2 : 1106820

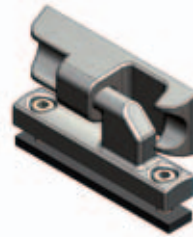
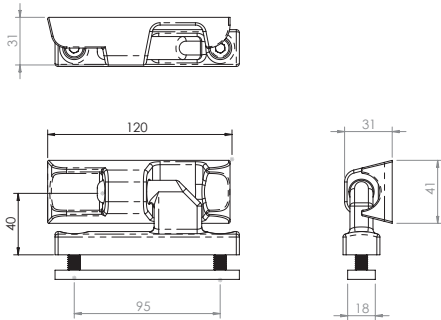

Onderbordscharnier als complete set, gegalvaniseerd.
Gewicht: 0,89 kg

Charnière de ridelle ensemble complet galvanisée.
Poids: 0,89 kg

Onderbordscharnier losse delen / Charnière de ridelle pièces détachées

C1.2 : 1106821

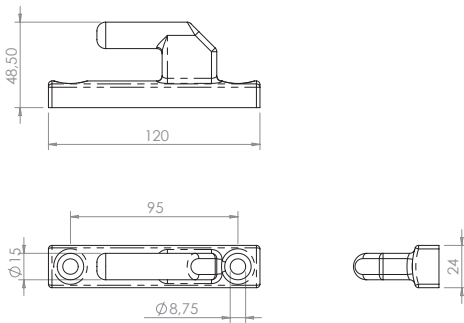

Scharnieren voor 1106820, gegalvaniseerd met 2 gaten.
Gewicht: 0,39 kg

Axe de charnière de 1106820, galvanisé 2 trous.
Poids: 0,39 kg

Onderbordscharnier losse delen / Charnière de ridelle pièces détachées

C1.2 : 1106822

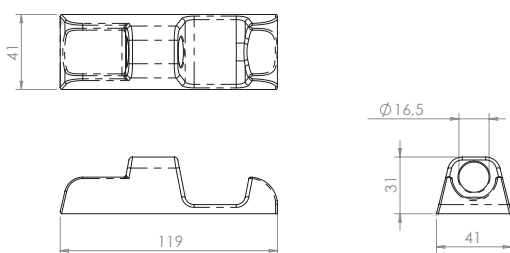

Houder voor onderbordscharnier gegalvaniseerd.
Gewicht: 0,27 kg

Support pour charnière de ridelle, galvanisé.
Poids: 0,27 kg

Onderbordscharnier sets / Charnière de ridelle ensembles

C1.2 : 1106830

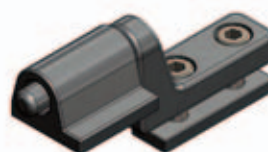
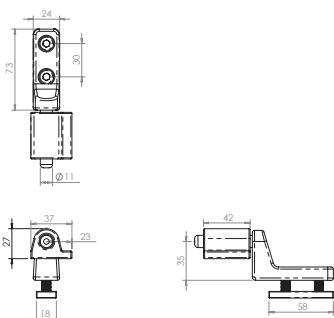

Onderbordscharnier als complete set gegalvaniseerd.
Gewicht: 0,48 kg

Charnière de ridelle ensemble complet galvanisé.
Poids: 0,48 kg



Scharnieren Charnières

C1.2

C1.2: 1106831

Onderbordscharnier losse delen / Charnière de ridelle pièces détachées

Onderbordscharnieren verzinkt,
voor 1106832.
Gewicht: 0,22 kg

Axe de charnière de ridelle, galvanisé
pour 1106832.
Poids: 0,22 kg

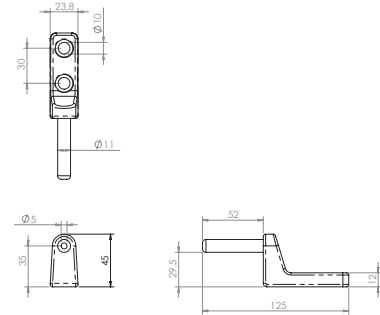

C1.2: 1106832

Onderbordscharnier losse delen / Charnière de ridelle pièces détachées

Onderbordscharnierhouder blank,
voor 1106831.
Gewicht: 0,19 kg

Axe de charnière de ridelle, nu, pour
1106831.
Poids: 0,19 kg

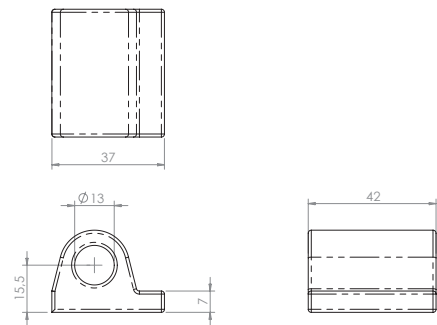

C1.2: 1106833

Onderbordscharnier losse delen / Charnière de ridelle pièces détachées

Inlegplaatje voor onderbordschar-
nier gegalvaniseerd 2 gaten.
Gewicht: 0,04 kg

Barette pour charnière de rid.
Poids: 0,04 kg

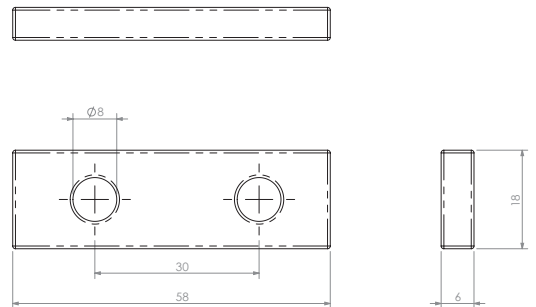
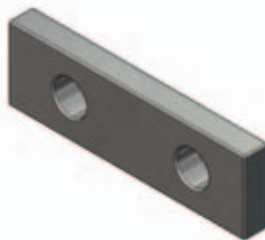

C1.2: 1106840

Onderbordscharnier sets / Charnière de ridelle ensembles

Onderbordscharnier als complete
set gegalvaniseerd klein.
Gewicht: 0,48 kg

Charnière de ridelle ensemble complet
galvanisé petit modèle.
Poids: 0,48 kg

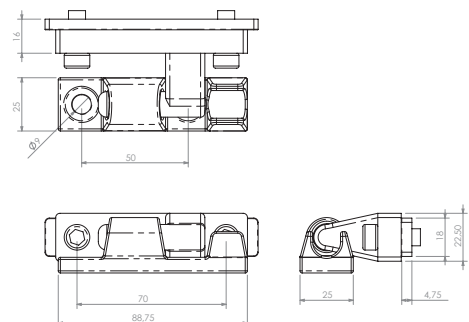
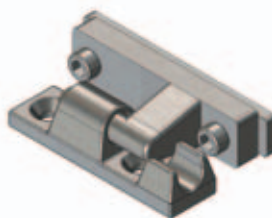



Onderbordscharnier sets / Charnière de ridelle ensembles

C1.2 : 1106855

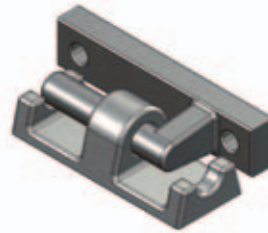
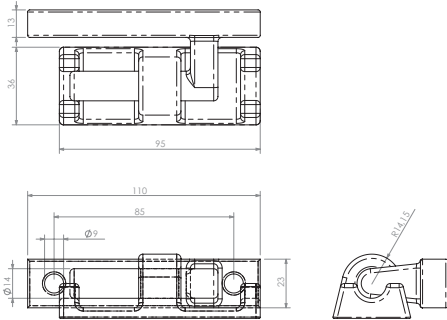

Onderbordscharnier verzinkt.
Gewicht: 0,14 kg

Charnière de ridelle, galvanisée.
Poids: 0,14 kg

Onderbordscharnier sets / Charnière de ridelle ensembles

C1.2 : 1189300

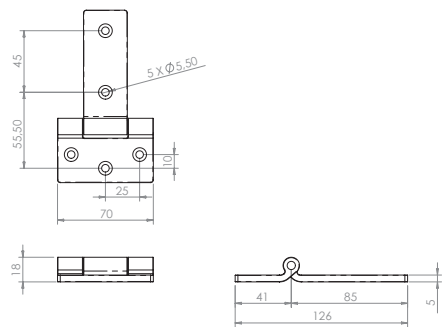

Zijdeurscharnier vlak aluminium.
Gewicht: 0,10 kg

Charnière de porte latérale, plate,
aluminium.
Poids: 0,10 kg

Achterbordscharnier zonder vergrendeling / Charnière arrière sans verrouillage

C1.3 : 1110439

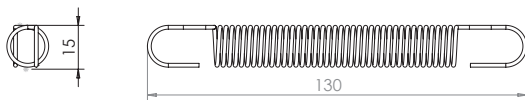

Veer.
Gewicht: 0,04 kg

Ressort.
Poids: 0,04 kg

Profielscharnier aluminium / Charnière de profilé aluminium

C1.4 : 1115240

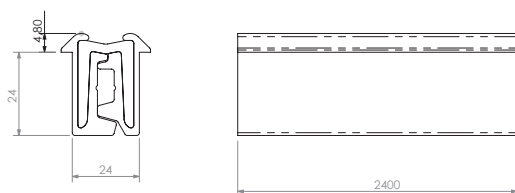

Aluminium rubber scharnier 24 /
2400 mm, 180 gram.
Gewicht: 2,96 kg

Charnière alurub 24 / 2400 mm, 180
g.
Poids: 2,96 kg